

## SR517D/SR517W

### ARCHITECTURAL CONTROLLER

Version: 1.0

Date: 10/3/2023

**TABLE OF CONTENTS**

<b>DESCRIPTION</b>	<b>3</b>
<b>SR517D INSTALLATION</b>	<b>3</b>
CONNECTIONS	3
POWER CONNECTIONS	3
DMX CONNECTIONS	3
REMOTE CONNECTIONS	3
PUSHBUTTON SMART REMOTE CONNECTIONS	3
SIMPLE SWITCH REMOTE STATIONS	4
<b>SR517W INSTALLATION</b>	<b>4</b>
CONNECTIONS	4
POWER CONNECTIONS	5
DMX CONNECTIONS	5
REMOTE CONNECTIONS	5
PUSHBUTTON SMART REMOTE CONNECTIONS	5
SIMPLE SWITCH REMOTE STATIONS	5
<b>SR517 CONFIGURATION SETUP</b>	<b>5</b>
RECORD BUTTON	6
ACCESSING AND SETTING FUNCTIONS	6
SETTING FADE TIMES	6
SIMPLE REMOTE SWITCH BEHAVIOR	6
SETTING SIMPLE SWITCH INPUT OPTIONS	7
SETTING SYSTEM CONFIGURATION OPTIONS 1	7
SETTING SYSTEM CONFIGURATION OPTIONS 2	7
CONTROLLING EXCLUSIVE SCENE ACTIVATION	8
SETTING SCENES TO BE PART OF A MUTUALLY EXCLUSIVE GROUP	8
DMX FIXED CHANNELS (PARKING)	8
SETTING DMX FIXED CHANNELS (PARKING)	8
FACTORY RESET	8
TO PERFORM A FACTORY RESET	8
<b>OPERATION</b>	<b>9</b>
DMX INDICATOR LIGHT	9
SCENE BANKS	9
TO RECORD A SCENE	9
SCENE ACTIVATION	9
TO ACTIVATE A SCENE	9
THE OFF BUTTON	9
RECALL LAST SCENE	9
BUTTON SCENES OFF	9
<b>MAINTENANCE AND REPAIR</b>	<b>10</b>
TROUBLESHOOTING	10
OWNER MAINTENANCE	10
CLEANING	10
REPAIRS	10
OPERATING AND MAINTENANCE ASSISTANCE	10
<b>WARRANTY</b>	<b>10</b>
<b>SR517 CONFIGURATION SETUP MENU</b>	<b>11</b>

**DESCRIPTION**

The SR517 provides simplified remote control for DMX lighting systems. The unit can store up to 16 lighting scenes and activate them with the push of a button. Scenes are organized in two banks of eight scenes each. Scenes in the SR517 can operate in either an “exclusive” mode (one scene active at a time) or in a “pile-on” mode which enables multiple scenes to be added together. Active scenes “pile-on” to any DMX input signal.

The unit can operate in conjunction with Lightronics smart remotes and simple remote switches for control at multiple locations. These remotes are wall mount units and connect to the SR517 via low voltage wiring and can turn SR517 scenes on and off.

This unit can be used for lighting system operation without the use of a DMX controller once scenes are recorded. The SR517 retains stored scenes when powered off.

The SR517 has a different programming menu from the previous SR models. There are also new features including button scene deactivation, once DMX is applied, and DMX address parking.

**SR517D INSTALLATION**

The SR517D is portable and is intended to be used on a desktop or other suitable horizontal surface.

**CONNECTIONS**

**TURN OFF ALL CONSOLES, DIMMER PACKS AND POWER SOURCES BEFORE MAKING EXTERNAL CONNECTIONS TO THE SR517D.**

The SR517D is provided with connectors on the rear edge of the unit for power, DMX input, DMX output, and remote stations. Tables and diagrams for connections are included in this manual.

**POWER CONNECTION**

The external power connector on the rear of the unit is a 2.1mm plug. The center pin is the positive (+) side of the connector. The provided 12VDC, 2 amp power supply requires a 120vac outlet.

**DMX CONNECTIONS**

A five pin MALE XLR connector is used to connect a DMX lighting controller (needed to create scenes). A five pin FEMALE XLR connector is used to connect to [www.lightronics.com](http://www.lightronics.com)

other DMX devices.

DMX signals should be carried by a shielded, twisted pair, low capacitance (25 pF/foot or less) cable.

DMX signal identification is shown in the table below. It applies to both the MALE and FEMALE connectors. Pin numbers are visible on the connector.

Connector Pin #	Signal Name
1	DMX Common
2	DMX DATA -
3	DMX DATA +
4	Not Used
5	Not Used

**REMOTE CONNECTIONS**

The SR517D can operate with two types of remote wall stations. The first type is Lightronics pushbutton smart remote stations. These remotes include the Lightronics line of AC, AK, and AI remote stations. Multiple pushbutton remotes of mixed models can be connected on this bus. The other type is simple momentary switch closures. Both remote types connect to the SR517D via a 9 pin (DB9) connector on the rear edge of the unit. The DB9 connector pin assignments are shown in the table below. Pin numbers are visible on the connector face.

Connector Pin #	Signal Name
1	Simple Switch Common
2	Simple Switch #1
3	Simple Switch #2
4	Simple Switch #3
5	Simple Switch Common
6	Smart Remote Common
7	Smart Remote DATA -
8	Smart Remote DATA +
9	Smart Remote Voltage +

Refer to the wall remote owner’s manuals for specific wiring instructions for connections at the remote.

**PUSHBUTTON SMART REMOTE CONNECTIONS**

Communication with these stations is over a four wire daisy chain bus which consists of a dual twisted pair data cable(s). One pair carries the data (Remote DATA - and Remote DATA +). These connect to pin 7 & 8 of the DB9 connector. The other pair supplies power to the stations (Remote Common and Remote

Voltage +). These connect to pin 6 & 9 of the DB9 connector.

An example using two Lightronics AC1109 smart remote wall stations is shown below.

**SR517D SMART REMOTE EXAMPLE**

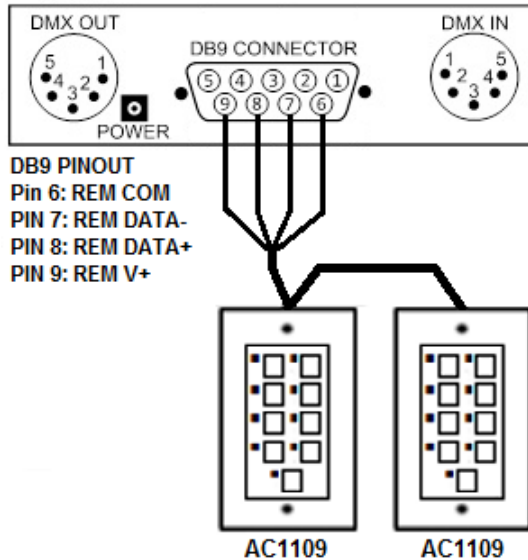

**SIMPLE SWITCH REMOTE STATIONS**

The first five pins of the DB9 connector are used to connect simple switch remote signals. They are COM, SWITCH 1, SWITCH 2, SWITCH 3, COM. The two SIMPLE COM terminals are connected to each other internally.

The following diagram shows an example using two simple switches. The example uses a Lightronics APP01 switch station and an APP11 momentary pushbutton switch. Several other user designed schemes could be used to wire these switches.

**SR517D SIMPLE SWITCH REMOTE EXAMPLE**

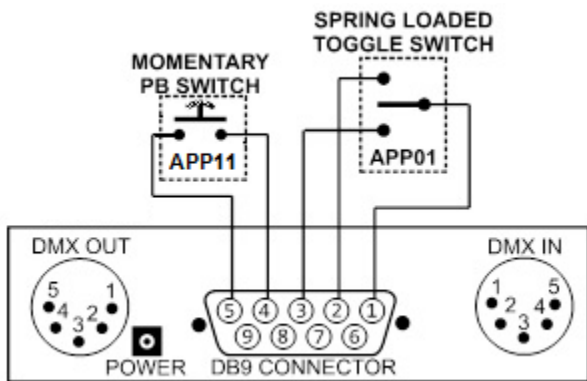

If the simple switch functions are set to factory default operation, the switches will operate as follows for the

connection example shown above.

1. Scene #1 will be turned ON when the toggle switch is pushed up.
2. Scene #1 will be turned OFF when the toggle switch is pushed down.
3. Scene #2 will be turned ON or OFF each time the momentary pushbutton switch is pushed.

**SR517W INSTALLATION**

The SR517W installs in a standard double gang wall switch box. A trim plate is supplied.

**NOTE: Install in a grounded metal box or in a plastic box with a ground wire from the metal faceplate to ground.**

**CONNECTIONS**

**TURN OFF ALL CONSOLES, DIMMER PACKS AND POWER SOURCES BEFORE MAKING EXTERNAL CONNECTIONS TO THE SR517W.**

The SR517W is provided with plug-in screw terminal connectors on the rear of the unit for power, DMX input, DMX output, and remote stations. Connection terminals are marked as to their function or signal. The connectors can be removed by carefully pulling them away from the circuit board.

**SR517W EXTERNAL CONNECTIONS**

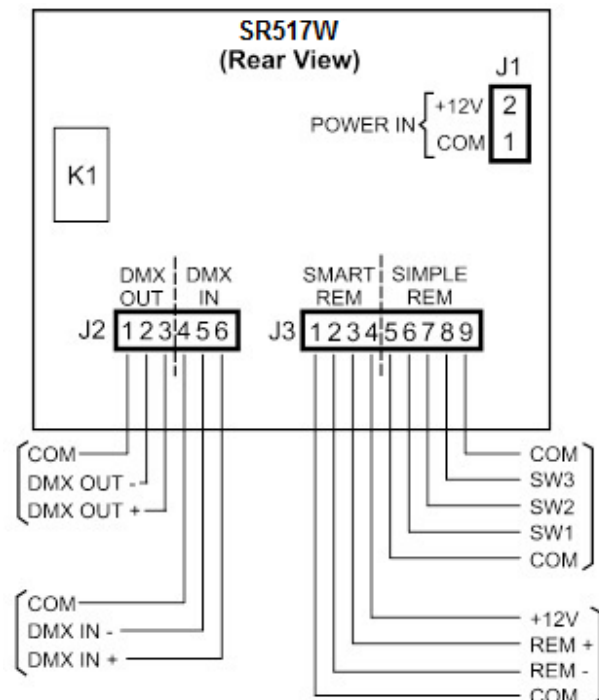

**POWER CONNECTIONS**

A two pin connector is provided for power. The connector terminals are marked on the circuit card to indicate the required polarity. Correct polarity **MUST BE OBSERVED AND MAINTAINED**. The provided 12VDC, 2 amp power supply requires a 120vac outlet.

**DMX CONNECTIONS**

Three terminals are used to connect a DMX lighting controller (needed to create scenes). They are marked as COM, DMX IN -, and DMX IN +. There are similar connections for DMX output to the rest of the DMX system. They are marked as COM, DMX OUT -, and DMX OUT +.

The DMX signal should be transmitted over a twisted pair, shielded, low capacitance (25 pF/foot or less) cable.

**REMOTE CONNECTIONS**

The SR517W can operate with two types of remote wall stations. The first type is Lightronics pushbutton smart remote stations. These remotes include the Lightronics line of AC, AK, and AI remote stations. Multiple pushbutton smart remotes of mixed types can be connected on this bus. The other type is simple momentary switch closures.

**PUSHBUTTON SMART REMOTE CONNECTIONS**

Communication with these stations is over a four wire daisy chain bus which consists of a dual twisted pair data cable(s). One pair carries the data (REM - and REM +). The other pair supplies power to the stations (COM and +12V).

Refer to the smart remote station owner's manuals for specific wiring instructions at the remote.

**SR517W SMART REMOTE EXAMPLE**

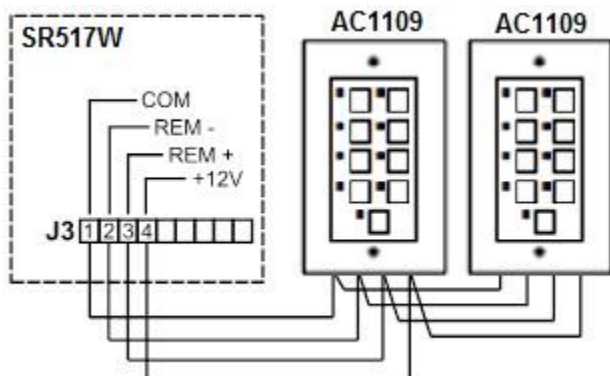

**SIMPLE SWITCH REMOTE STATIONS**

Five terminals are used to connect simple switch remote signals. They are marked as COM, SWITCH 1, SWITCH 2, SWITCH 3, COM. The simple remote COM terminals are connected to each other on the printed circuit board.

An example with two switch remotes is shown below.

**SIMPLE SWITCH REMOTE CONNECTIONS**

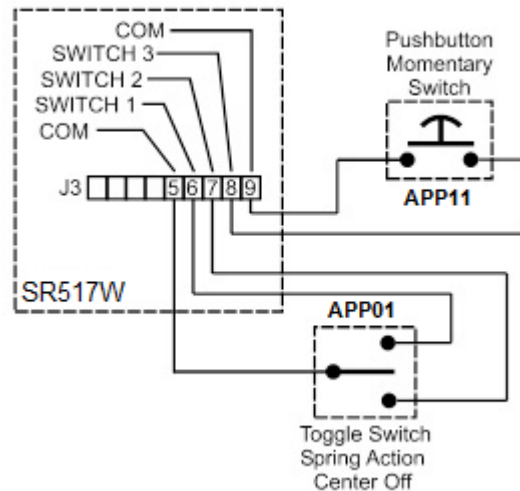

The example uses a Lightronics APP01 switch station and an APP11 momentary pushbutton switch. If the SR517W simple switch functions are set to factory default operation, the switches will operate as follows.

1. Scene #1 will be turned ON when the toggle switch is pushed up.
2. Scene #1 will be turned OFF when the toggle switch is pushed in the down.
3. Scene #2 will be toggled on or off each time the momentary pushbutton switch is pushed.

**SR517 CONFIGURATION SETUP**

The behavior of the SR517 is controlled by a set of function codes and their associated values. A full list of these codes and a brief description is shown below. Specific instructions for each function are provided in this manual. A diagram at the back of this manual gives a quick guide to programming the unit.

- 11 Bank A, Scene 1 Fade Time
- 12 Bank A, Scene 2 Fade Time
- 13 Bank A, Scene 3 Fade Time
- 14 Bank A, Scene 4 Fade Time
- 15 Bank A, Scene 5 Fade Time
- 16 Bank A, Scene 6 Fade Time

17	Bank A, Scene 7 Fade Time
18	Bank A, Scene 8 Fade Time
21	Bank B, Scene 1 Fade Time
22	Bank B, Scene 2 Fade Time
23	Bank B, Scene 3 Fade Time
24	Bank B, Scene 4 Fade Time
25	Bank B, Scene 5 Fade Time
26	Bank B, Scene 6 Fade Time
27	Bank B, Scene 7 Fade Time
28	Bank B, Scene 8 Fade Time
31	Blackout (OFF) Fade Time
32	ALL Scenes and Blackout Fade Time
33	Simple Switch Input #1 Options
34	Simple Switch Input #2 Options
35	Simple Switch Input #3 Options
36	Not Used
37	System Configuration Options 1
38	System Configuration Options 2
41	Mutually Exclusive Group #1 Scenes
42	Mutually Exclusive Group #2 Scenes
43	Mutually Exclusive Group #3 Scenes
44	Mutually Exclusive Group #4 Scenes
88	DMX Fixed Channel Recording (Parking) and Factory Reset

## RECORD BUTTON

This is a small recessed pushbutton in a small hole in the faceplate. It is just below the RECORD LED (labeled REC). You will need a small rod (such as a pen or paper clip) to push it.

## ACCESSING AND SETTING FUNCTIONS

1. Hold down REC for more than 3 seconds. The REC light will begin blinking. The unit will return to its normal operating mode after about 20 seconds if step 2 is not performed.
2. Push RECALL. The RECALL and REC lights will blink alternately.
3. Enter a 2 digit function code using the scene buttons (1 - 8). The scene lights will flash a repeating pattern of the code entered. The unit will return to its normal operating mode after about 20 seconds if no code is entered. The unit will return to its normal operating mode after about 60 seconds if a code is entered but step 4 is not performed.
4. Push RECALL. Both the RECALL and REC lights will be ON. The scene lights (in some cases including the OFF (0) and BANK (9) lights) will show the current function setting or value.

Your action now depends on which function was entered. Refer to the instructions for that function. You can enter new values and push REC to save them or push RECALL to exit without changing the values.

## SETTING FADE TIMES (Function Codes 11 - 32)

The fade time is the minutes or seconds to move between scenes or for scenes to go ON or OFF. The fade time for each scene can be individually set. The allowable range is from 0 seconds to 99 minutes.

Fade time is entered as 4 digits and can be either minutes or seconds.

Numbers entered from 0000 - 0099 will be recorded as seconds.

Numbers 0100 and larger will be recorded as even minutes and the last two digits will not be used. In other words, seconds will be ignored.

After accessing a function (11 - 32) as described in ACCESSING AND SETTING FUNCTIONS:

1. The scene lights + OFF (0) and BANK (9) lights will be flashing a repeating pattern of the current fade time setting.
2. Use the scene buttons to enter a new fade time (4 digits). Use OFF for (0) and BANK for (9) if needed.
3. Push REC to save the new function setting.

Function Code 32 is a master fade time function which will set ALL fade times to the value entered. You can use this for a base setting for fade times and then set individual scenes to other times as needed.

## SIMPLE REMOTE SWITCH BEHAVIOR

The SR517 is very versatile in how it can respond to the simple remote switch inputs. Each switch input can be set to operate according to its own settings.

Most settings pertain to momentary switch closures. The MAINTAIN setting allows the use of a regular ON/OFF switch. When used this way, the applicable scene(s) will be ON while the switch is closed and OFF when the switch is open.

Other scenes can still be activated and the OFF/Blackout function button will turn the MAINTAIN scene OFF.

**SETTING SIMPLE SWITCH INPUT OPTIONS**

(Function Codes 33 - 35)

After accessing a function as described in ACCESSING AND SETTING FUNCTIONS:

1. The scene lights, including OFF (0) and BANK (9), and will flash a repeating pattern of the current setting.
2. Use the scene buttons to enter a value (4 digits). Use OFF for (0) and BANK A/B for (9) if needed.
3. Push REC to save the new function value.

The function values and description are as follows:

**SCENE ON/OFF CONTROL**

0101 - 0116 Turn ON Scene (1-16)  
0201 - 0216 Turn OFF Scene (1-16)  
0301 - 0316 Toggle ON/OFF Scene (1-16)  
0401 - 0416 MAINTAIN Scene (1-16)

**OTHER SCENE CONTROLS**

0001 Ignore this switch input  
0002 Blackout - turn off all scenes  
0003 Recall last scene(s)

**SETTING SYSTEM CONFIGURATION OPTIONS 1**

(Function Code 37)

The system configuration options are specific behaviors which can be turned ON or OFF.

After accessing a function code (37) as described in ACCESSING AND SETTING FUNCTIONS:

1. The scene lights (1 - 8) will show which options are on. An ON light means the option is active.
2. Use the scene buttons to toggle the associated option ON and OFF.
3. Push REC to save the new function setting.

The configuration options are as follows:

**SCENE 1 REMOTE BUTTON STATION LOCKOUT**  
Disables smart remote pushbutton stations if a DMX input signal is present.

**SCENE 2 NOT APPLICABLE TO SR517**

**SCENE 3 SIMPLE REMOTE INPUT LOCKOUT**  
Disables simple remote inputs if a DMX input signal is present.

**SCENE 4 LOCAL BUTTON LOCKOUT**  
Disables SR517 pushbuttons if a DMX input signal is present.

**SCENE 5 SAVED FOR FUTURE EXPANSION**

**SCENE 6 BUTTON SCENES OFF**  
Turns off button scenes once a DMX input signal is initially applied from a no DMX input status.

**SCENE 7 SAVED FOR FUTURE EXPANSION**

**SCENE 8 ALL SCENES RECORD LOCKOUT**  
Disables scene recording. Applies to all scenes.

**SETTING SYSTEM CONFIGURATION OPTIONS 2**  
(Function Code 38)

The system configuration options are specific behaviors which can be turned ON or OFF.

After accessing a function code (38) as described in ACCESSING AND SETTING FUNCTIONS:

1. The scene lights (1 - 8) will show which options are on. An ON light means the option is active.
2. Use the scene buttons to toggle the associated option ON and OFF.
3. Push REC to save the new function setting.

**SCENE 1 SAVED FOR FUTURE EXPANSION**

**SCENE 2 MASTER/SLAVE MODE**  
Changes the SR517 from transmit mode to receive mode when a master dimmer (ID 00) or another SC/SR unit is already in the system.

**SCENE 3 SAVED FOR FUTURE EXPANSION**

**SCENE 4 CONTINUOUS DMX TRANSMISSION**  
SR517 will continue to send DMX data at 0 values with no DMX input or no scenes active rather than no DMX signal output.

**SCENE 5 RETAIN PREVIOUS SCENE(S) FROM POWER OFF**

If a scene was active when the SR517 was powered off, it will turn on that scene when power is restored.

**SCENE 6 MUTUALLY EXCLUSIVE GROUP - ONE ON REQUIREMENT**

Disables the ability to turn off all scenes in a mutually exclusive group. It forces the last live scene in the group to stay on, unless you push OFF/Blackout.

**SCENE 7 DISABLE FADE INDICATION**

Prevents the scene lights from blinking during scene fade time.

**SCENE 8 DMX FAST TRANSMIT**

Reduces the DMX interslot time from 3µsec to 0µsec to reduce the overall DMX frame to 41µsec.

**CONTROLLING EXCLUSIVE SCENE ACTIVATION**

During normal operation, multiple scenes can be active at the same time. Channel intensities for multiple scenes will combine in a "greatest of" manner.

You can cause a scene, or multiple scenes, to operate in an exclusive manner by making them part of a mutually exclusive group.

There are four groups which can be set. If scenes are part of a group, then only one scene in the group can be active at any given time.

Other scenes (not part of that group) can be on at the same time as scenes in a group.

Unless you are going to set one or two simple groups of non-overlapping scenes, you may want to experiment with the settings to get different effects.

**SETTING SCENES TO BE PART OF A MUTUALLY EXCLUSIVE GROUP** (Function Codes 41 - 44)

After accessing a function (41 - 44) as described in ACCESSING AND SETTING FUNCTIONS:

1. The scene lights will show which scenes are part of the group. Use the BANK A/B button as needed to check both banks.
2. Use the scene buttons to toggle scenes on/off for the group.
3. Push REC to save the new group set.

**FIXED DMX CHANNELS (PARKING)**

DMX channels can be assigned a fixed output level or be "parked" at any value above 1%. When a DMX channel is assigned a fixed value, the output will

remain at that value and cannot be overridden by scene recalls or by independent DMX control.

**SETTING DMX FIXED CHANNELS (PARKING)**  
(FUNCTION 88)

To record a DMX channel to a FIXED output:

1. Set the values associated with the DMX channel to the level(s) desired on your DMX controller.
2. Press the REC button for 3 seconds until the REC and 1-8 LEDs begin to flash.
3. Press the RECALL button (begins to flash) and press 88.
4. Press RECALL. The RECALL and REC LEDs are now on solid.
5. Press 3327, then wait for the LEDs to flash acknowledging your entry.
6. Press the REC button to record the change.

**Note:** To erase a fixed channel output, follow the steps above setting the level for each of the DMX channels to regain normal operation to a value of 0.

**Note:** Document which channels have been parked, for reference, and so they can be changed later if needed.

**FACTORY RESET** (Function Code 88)

A Factory Reset will invoke the following conditions:

1. All scenes will be erased.
2. All fade times will be set to two seconds.
3. Simple switch functions will be set as follows:
  - Input #1 Turn ON Scene 1
  - Input #2 Turn OFF Scene 1
  - Input #3 Toggle Scene 2 ON and OFF
4. All System Configuration Options (Function Codes 37 and 38) will be turned OFF.
5. Mutually Exclusive groups will be cleared (no scenes in the groups).
6. DMX Fixed Channel settings will be cleared.

**TO PERFORM A FACTORY RESET:**

After accessing a function (88) as described in ACCESSING AND SETTING FUNCTIONS:

1. The OFF (0) light will repeat a pattern of 4 flashes.

2. Enter **0517** (the model number of the product).
3. Push REC. The scene lights will flash briefly and the unit will return to its operating mode.

## OPERATION

The SR517 turns on automatically when power is applied from the external power supply. There is no ON/OFF switch or button.

When an SR517 is not powered, a DMX signal fed to the DMX IN connector (if connected) is directly routed to the DMX OUT connector.

## DMX INDICATOR LIGHT

This indicator conveys the following information about the DMX input and DMX output signals.

1. OFF           DMX is NOT being received.  
DMX is NOT being transmitted.  
(No scenes are active).
2. BLINKING   DMX is NOT being received.  
DMX IS being transmitted.  
(One or more scenes are active).
3. ON            DMX is being received.  
DMX is being transmitted.

## SCENE BANKS

The SR517 can store 16 operator created scenes and activate them with the push of a button. Scenes are organized in two banks (A and B). A bank switch button and indicator are provided for switching between banks. Bank "B" is active when the BANK A/B light is on.

## TO RECORD A SCENE

A DMX control device must be connected and used to create the scene to be stored in the SR517.

Check that Scene Record Lockout is OFF.  
(Function 37.8)

1. Create a scene using the control console faders to set dimmer channels to the desired levels.
2. Select the bank where you want to store the scene.
3. Hold down REC on the SR517 until the REC LED and the scene lights begin to flash (about 3 sec.).

4. Push the button for the scene you want recorded.

The REC and scene lights will go OFF which shows that recording was completed.

The REC and scene lights will stop flashing after about 20 seconds if you do not select a scene.

5. Repeat steps 1 through 4 to record other scenes.

## SCENE ACTIVATION

Playback of scenes stored in the SR517 will occur regardless of control console operation or status. This means that scenes activated from the unit will add to or "pile on" to the channel data from a DMX console.

## TO ACTIVATE A SCENE

1. Set the SR517 to the desired scene bank.
2. Push the button associated with the desired scene. The scene will fade in according to the fade time function settings.

The scene light will blink until the scene reaches its full level. It will then be ON. The blink action can be disabled by a configuration option.

The scene activation buttons are toggles. To turn off an active scene – push its associated button.

Scene activation can be either "exclusive" (only one scene may be active at a time) or "pile on" (multiple scenes on at the same time) depending on setup function selections. During "pile on" operation - multiple active scenes will combine in a "greatest of" fashion with respect to channel intensity.

## THE OFF BUTTON

The OFF button blacks out or turns off all active scenes. Its indicator is on when active.

## RECALL LAST SCENE

The RECALL button can be used to reactivate the scene or scenes which were on prior to an OFF condition. The RECALL indicator will light when a recall is in effect. It will not step back through a series of previous scenes.

## BUTTON SCENES OFF (Function 37.6)

When this feature is active, the SR517 will blackout or

turn off all active button scenes when a DMX input is initially received after a no DMX input status. There is no automatic scene activation once DMX is no longer applied to the SR517.

## **MAINTENANCE AND REPAIR**

### **TROUBLESHOOTING**

1. A valid DMX control signal must be present to record a scene.
2. If a scene does not activate correctly – it may have been overwritten without your knowledge.
3. If you cannot record scenes – check that the record lockout option is not on. See Function 37.8.
4. Check that the DMX cables and/or remote wiring are not defective. **A MOST COMMON PROBLEM SOURCE.**
5. To simplify troubleshooting - set the unit to known set of conditions. A factory reset can be performed. See Function 88.
6. Make sure the fixture or dimmer addresses are set to the desired channels.
7. Check that the controller softpatch (if applicable) is set correctly.
8. If DMX devices are operating unexpectedly, determine if Fixed DMX addresses are programmed in the SR517. See Function 88.

## **OWNER MAINTENANCE**

### **CLEANING**

The best way to prolong the life of your SR517 is to keep it dry, cool, and clean.

**COMPLETELY DISCONNECT THE UNIT BEFORE CLEANING AND MAKE SURE IT IS COMPLETELY DRY BEFORE RECONNECTING.**

The unit exterior may be cleaned using a soft cloth dampened with a mild detergent/water mixture or a mild spray-on type cleaner. **DO NOT SPRAY ANY AEROSOL OR LIQUID** directly on the unit. **DO NOT IMMERS**E the unit in any liquid or allow liquid to get into the controls. **DO NOT USE** any solvent based or abrasive cleaners on the unit.

## **REPAIRS**

There are no user serviceable parts in the unit. Service by other than Lightronics authorized agents will void your warranty.

## **OPERATING AND MAINTENANCE ASSISTANCE**

Dealer and Lightronics technical support personnel can help you with operation or maintenance problems. Please read the applicable parts of this manual before calling for assistance.

If service is required - contact the dealer from whom you purchased the unit or contact Lightronics, Service Dept., 509 Central Drive, Virginia Beach, VA 23454 TEL: (757) 486-3588.

## **WARRANTY INFORMATION AND REGISTRATION – CLICK LINK BELOW**

[www.lightronics.com/warranty.html](http://www.lightronics.com/warranty.html)

SR517 CONFIGURATION SETUP MENU

