



ARCHITECTURAL SERIES

AR1202 RTC

12 CHANNEL X 2.4KW

AR1202-6 RTC

6 CHANNEL X 2.4KW

OWNER'S MANUAL

Revision 2.01
05/01/2026

AR1202RTC ARCHITECTURAL DIMMER

Revision 2.01

OWNER'S MANUAL

05/01/2026

TABLE OF CONTENTS

AR1202 UNIT DESCRIPTION	3	EVENT SYSTEM OPERATION	15
EXTERNAL CONTROLS	3	Event System Enable	15
REAL TIME CLOCK EVENT SYSTEM	3	To Control Event Triggering	15
POWER REQUIREMENTS	3	Setting the Internal Clock	15
INSTALLATION	3	Setting the Date	15
Physical Location	3	Setting the Time of Day	15
Power Input Connections	3	Setting the Day of the Week	16
Three Phase Power Connections	4	Programming Events	16
Single Phase Power Connections	5	Selecting an Event	16
External Connections	6	Assigning a Scene and Scene Action	17
Lighting Load Connections	6	Choosing Date Based or Day Based Triggers	17
Control Signal Connections	6	Setting Date Based Triggers	17
DMX Controller Connections	7	Setting Day Based Triggers	17
DMX Termination	7	MAINTENANCE AND REPAIR	18
Smart Remote Connections (LitNet)	8	Owner Maintenance	18
Simple Remote Connections	9	Internal Fuse	18
AR1202 Unit Setup	9	Troubleshooting	18
Using the Menu System	10	Operating and Maintenance Assistance	18
System Mode	10	WARRANTY REGISTRATION	18
System Power Setup	10	CONTROL CIRCUIT BOARD CONNECTIONS	19
Unit Address Assignment	11	DIMENSIONS AND MOUNTING	20
Dimmer Channel Setup	11	AR1202 UNIT SPECIFICATIONS	21
Channel Limiting	11		
Channel Dimmer/Non-Dim Mode	11		
DMX I/O Setup (Dimmer Channel Assignment)	12		
DMX Lockout	12		
Smart Remote Lockout	12		
Creating And Editing Scenes	12		
To Create a Scene Manually	12		
To Copy a Scene	13		
To Record a Live Scene	13		
Scene Fade Time	13		
Scene Blackout Fade Time	13		
OPERATION	13		
Manual Operation	13		
DMX Controller Operation	14		
Smart Remotes Operation (LitNet)	14		
Button and IR Smart Remotes Operation	14		
Fader Smart Remotes Operation	14		
Simple Remotes Operation	14		

AR1202RTC ARCHITECTURAL DIMMER

Revision 2.01

OWNER'S MANUAL

05/01/2026

AR1202RTC UNIT DESCRIPTION

The AR1202RTC is a FORWARD PHASE/LEADING EDGE dimmer that consists of an embedded micro-processor. The AR1202RTC has 12 channels of 2.4KW each. The AR1202-6RTC has 6 channels of 2.4KW each. Each dimmer channel is protected by a 20 amp circuit breaker. Heavy duty filtering chokes are used to reduce filament noise. Dimmer channel SCRs exceed a 200% load carrying capacity overhead allowance. The AR1202RTC conforms to UL standards as they apply to industrial control equipment. Product specifications are provided at the end of this manual. The AR1202RTC & AR1202-6RTC will simply be referred to as AR1202 and AR1202-6 in this manual unless there are differences in the models.

EXTERNAL CONTROLS

The AR1202 can communicate with remotely located control equipment in several ways.

A USITT DMX512 protocol bus is provided so the unit may be used with any DMX lighting controller. The AR1202 is fully patchable with respect to the DMX bus.

The AR1202 may also be controlled by several types of wall mounted smart remote stations. Smart remotes communicate with the AR1202 over LitNet. This is a Lightronics proprietary low voltage RS-485 bus. This bus is completely separate from the DMX bus. Smart remotes are used to activate preset scenes which have been stored in the AR1202. There are several types of smart remote stations. Multiple smart remotes of the same or different types may be daisy chained together. Multiple AR/AB/RA model dimmers and architectural controllers may also be daisy chained together on LitNet.

The AR1202 may additionally be controlled by an arrangement of one or more momentary contacts (simple remotes). These contacts may be used to control a specific set of scenes stored in the AR1202. The AR1202 follows a 'Last Takes Precedence' hierarchy between DMX and remote operation.

REAL TIME CLOCK EVENT SYSTEM

The AR1202 contains an internal clock and timer subsystem. This subsystem may be used to create events which activate and switch between preset lighting scenes based upon times, days, and dates. A total of 128 events may be programmed.

POWER REQUIREMENTS

The AR1202 may be operated from 50/60 Hz, 120/208 VAC, three phase power or from 50/60 Hz, 120/240 VAC, single phase power. Input power to the unit must be capable of delivering 80 amps per line if using three phase power or 120 amps per line if using single phase power. The AR1202-6 input source must be capable of delivering 40 amps per line if using three phase power or 60 amps per line if using single phase power.

The AR1202 can operate using only two phases of a three phase power source. However, this is NOT RECOMMENDED, since it causes an unbalanced load at the power feed source.

When using three phase power, the AR1202 must be used with a WYE connection power source. A NEUTRAL line and a separate GROUND line are required.

INSTALLATION

PHYSICAL LOCATION

The unit is intended for INDOOR OPERATION ONLY and should not be subjected to excessive moisture or heat. The unit should be installed where a supply of circulating air is available. The AR1202 is designed to be wall mounted in an equipment room or electrical distribution area. The ambient air in the installation area should be below 86° F.

The AR1202 dimming components are cooled by heatsinks on the sides of the unit. These are only on the left side of the AR1202-6. Additional cooling is provided by vents in the front, top and bottom of the AR1202. Provide spacing between the AR1202 and other equipment to allow air flow around the unit (particularly around the finned heat sinks).

See "Dimensions and Mounting" in this manual for more information concerning mounting of the unit.

POWER INPUT CONNECTIONS



WARNING



MAKE CERTAIN POWER IS REMOVED
FROM THE FEED CIRCUITS
BEFORE YOU BEGIN INSTALLATION.

Consult applicable electrical codes to determine the proper wire type and methods.

AR1202RTC ARCHITECTURAL DIMMER

Revision 2.01

OWNER'S MANUAL

05/01/2026

The AR1202 operates using either three phase 120/208 VAC or single phase 120/240 VAC power. The unit is shipped from the factory as a THREE PHASE unit. It can be field converted to a single phase unit.

THREE PHASE POWER CONNECTIONS

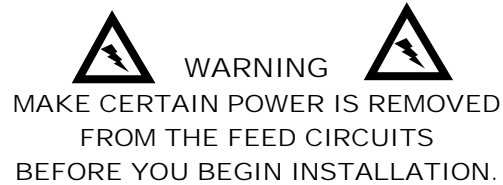

REQUIREMENTS

Actual 120/208VAC three phase power must be supplied to operate the AR1202 in the three phase configuration. This means that the voltage across any two lines must be 208 VAC. The feed circuit must be able to supply 80 amps for each hot line of the AR1202 (40 amps for each hot line of the AR1202-6).

THE AR1202 WILL NOT OPERATE IN A THREE PHASE CONFIGURATION FROM TWO LINES OF EITHER A SINGLE OR THREE PHASE SUPPLY CIRCUIT. SEE THE SINGLE PHASE POWER CONNECTIONS FOR INSTRUCTIONS.

CONNECTIONS

Connect the feed ground to the GROUND lug.

Connect the feed neutral to the NEUTRAL bus bar.

Connect the three hot feed lines to the three terminals on the input power terminal block (H1, H2, H3).

HIGH VOLTAGE CIRCUITRY IS EXPOSED WHEN THE CABINET DOOR IS OPEN. DO NOT ALLOW THE UNIT TO OPERATE OR HAVE POWER APPLIED TO IT WHILE THE DOOR IS OPEN.

THREE PHASE POWER CONNECTIONS

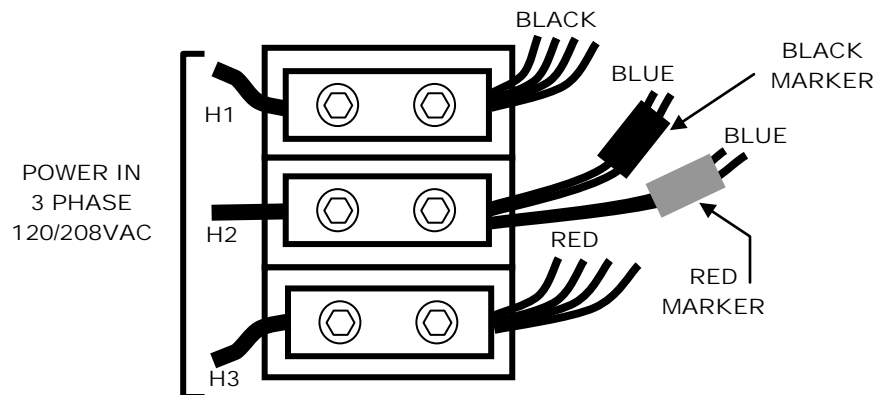



AR1202RTC ARCHITECTURAL DIMMER

Revision 2.01

OWNER'S MANUAL

05/01/2026

SINGLE PHASE POWER CONNECTIONS

 **WARNING** 
 MAKE CERTAIN POWER IS REMOVED
 FROM THE FEED CIRCUITS
 BEFORE YOU BEGIN INSTALLATION.

REQUIREMENTS

The single phase 120V feed circuits must be able to supply 120 amps for each line for the AR1202 (60 amps for each line for the AR1202-6).

These wiring instructions are also applicable if the only available feed circuits are two legs of three phase power. This is NOT RECOMMENDED since it causes an unbalanced load at the power source.

CONNECTIONS

There are three terminals on the input power terminal block (H1, H2, H3). When operating the AR1202 on single phase power, the center (H2) terminal is not used.

Connect the feed ground to the GROUND lug.

Connect the feed neutral to the NEUTRAL bus bar.

The wires connected to the right side of the H2 terminal contain color coded sleeves (RED and BLACK). These wires must be moved and distributed to the H1 and H3 terminals. Remove the wires from the H2 terminal and connect them to H1 and H3 such that the sleeve color matches the wire colors on H1 and H3. **Note:** On an AR1202-6 using two legs of three phase power, both blue wires on H2 will be moved to H1 in the CONNECTIONS diagram below.

HIGH VOLTAGE CIRCUITRY IS EXPOSED WHEN THE CABINET DOOR IS OPEN. DO NOT ALLOW THE UNIT TO OPERATE OR HAVE POWER APPLIED TO IT WHILE THE DOOR IS OPEN.

SINGLE PHASE POWER CONNECTIONS

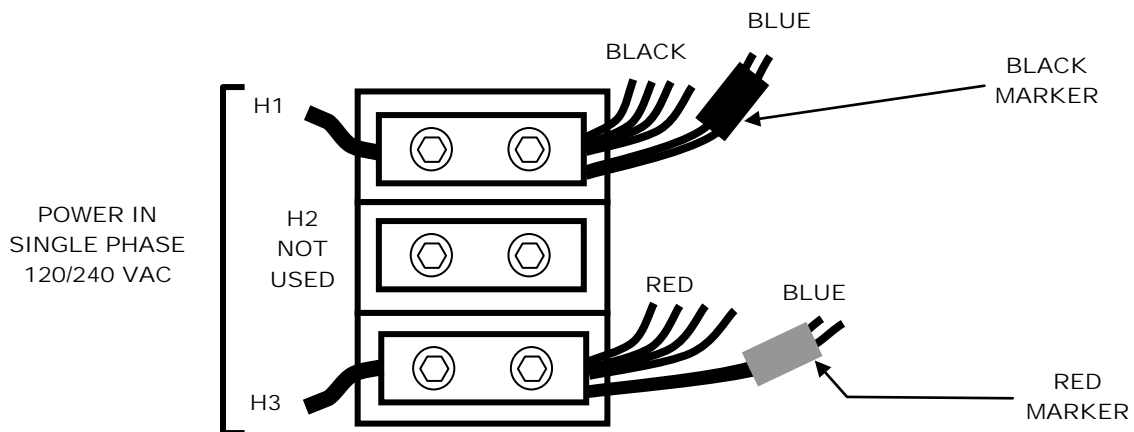

On an AR1202-6 using two legs of three phase power, both blue wires that have the black and red markers will be moved to H1.

AR1202RTC ARCHITECTURAL DIMMER
OWNER'S MANUAL

Revision 2.01

05/01/2026

EXTERNAL CONNECTIONS

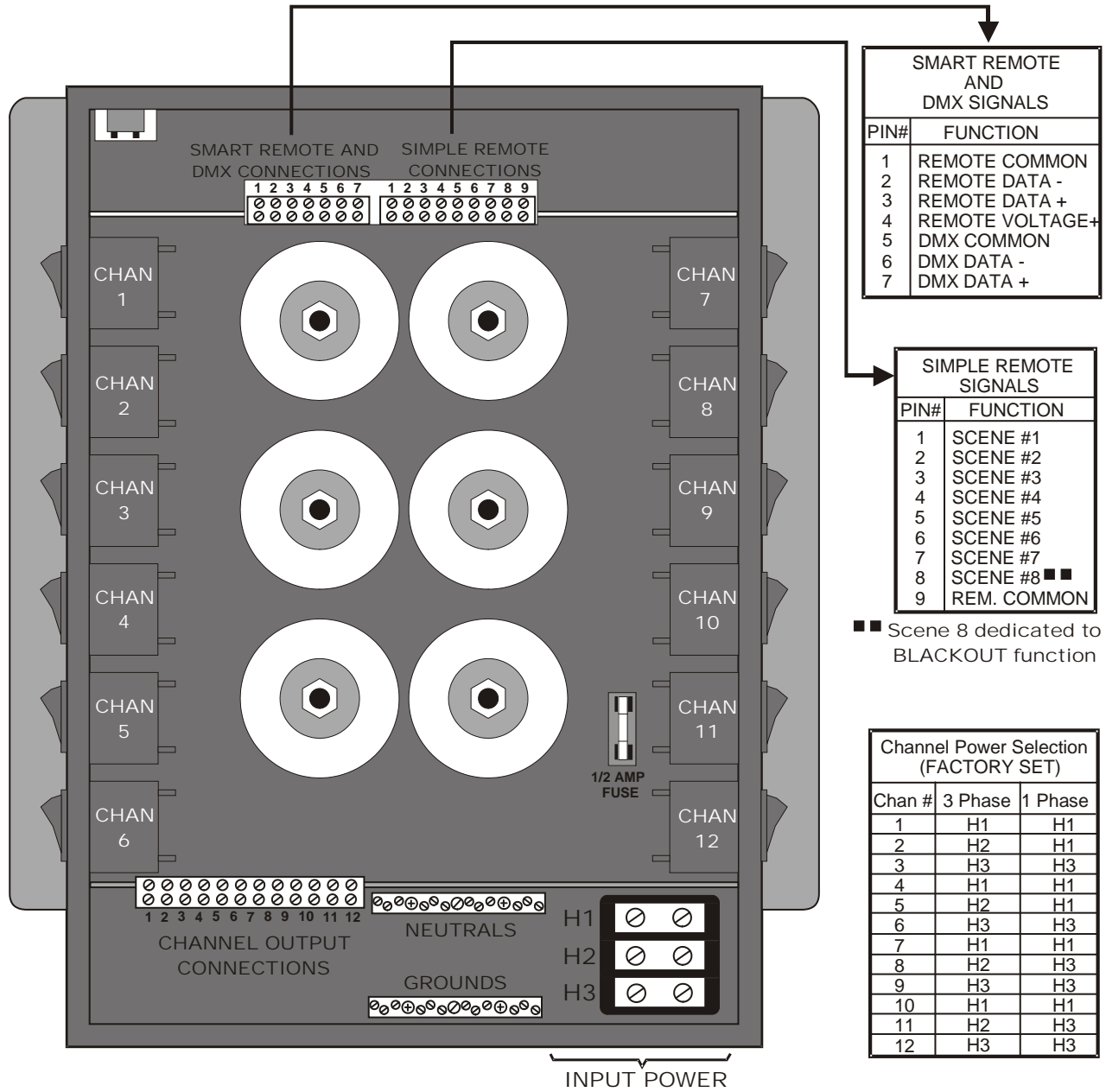

LIGHTING LOAD CONNECTIONS

Lighting to be controlled by the AR1202 must be connected to the terminal strip located on the front of the lower separator panel of the cabinet. The lowest number dimmer channel output connection is on the left. See the EXTERNAL CONNECTIONS DIAGRAM above. The load connections terminal strip is shown as CHANNEL OUTPUT CONNECTIONS in the diagram.

CONTROL SIGNAL CONNECTIONS

Terminal strips are provided for connection to DMX controllers, smart remotes, and simple remote stations. Specific wiring connection point information for all external control signals is shown in the EXTERNAL CONNECTIONS diagram above.

DMX CONTROLLER CONNECTIONS

DMX controller signals to the AR1202 should be transmitted over a shielded, twisted pair, low capacitance cable. Most DMX controllers transmit from a female, 5 Pin XLR Connector.

See the EXTERNAL CONNECTIONS and the example below for specific connection information.

DMX TERMINATION

A DMX bus should be terminated (only) at the last receiving device on the chain. This is done by connecting a 120 ohm, 1/4 watt resistor across the DMX DATA - and DMX DATA + lines.

A DMX bus should be daisy chained to all its receiving units. It should NOT be connected in a star configuration with multiple separate runs without an approved DMX optically isolated splitter.

CAUTION
 REMOVE ALL POWER FROM THE AR1202
 BEFORE MAKING OR CHANGING DMX
 CONTROLLER CONNECTIONS.

**DMX CABLE
 CONDUCTOR ARRANGEMENT FOR
 TWISTED PAIR, SHIELDED CABLE**

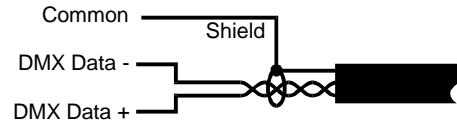

**CONTROLLER DMX OUTPUT
 CONNECTOR (5 PIN FEMALE XLR)**

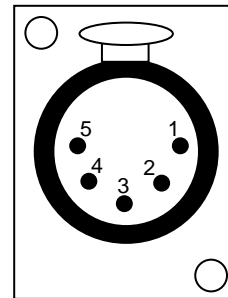

DMX CONNECTIONS EXAMPLE

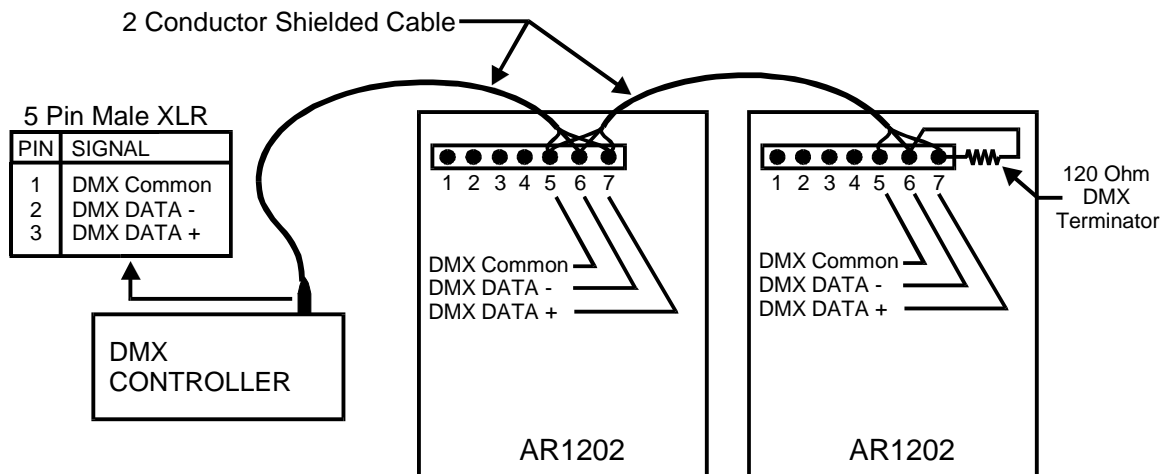

SMART REMOTE CONNECTIONS (LitNet)

There are two types of smart remotes (push button and fader) which can be used with the AR1202. There are multiple models of each type. They all connect to LitNet, which is a proprietary RS-485 bus that can be controlled by an AR1202. Additional AR/AB/RA dimmers may also be connected on the same bus and each can serve as a LitNet host. One of them will be set as the master host controller by making UNIT ADDRESS ASSIGNMENTS.

Smart remote signals to the AR1202 are transmitted over a shielded, two twisted pair, low capacitance cable. One pair carries the RS-485 signal and the other provides low voltage power and common to the remotes.

The LitNet bus should be daisy chained to all of its receiving units. It should NOT be connected in a star configuration with multiple separate runs.

Each smart remote has a 4-pin connector with screw down terminals to connect to the LitNet bus. You must get the correct wiring pinout information for each remote unit from its respective owner's manual.

CAUTION
 REMOVE ALL POWER FROM THE AR1202 BEFORE MAKING OR CHANGING SMART REMOTE CONNECTIONS.

See the diagram "EXTERNAL CONNECTIONS" and the example below for specific connection information.

SMART REMOTES CABLE CONDUCTOR ARRANGEMENT FOR DUAL TWISTED PAIR, SHIELDED CABLE

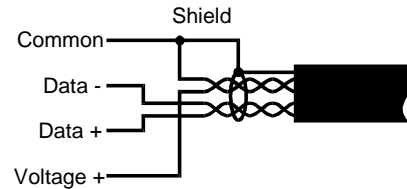

SMART REMOTE (LitNet) CONNECTIONS EXAMPLE

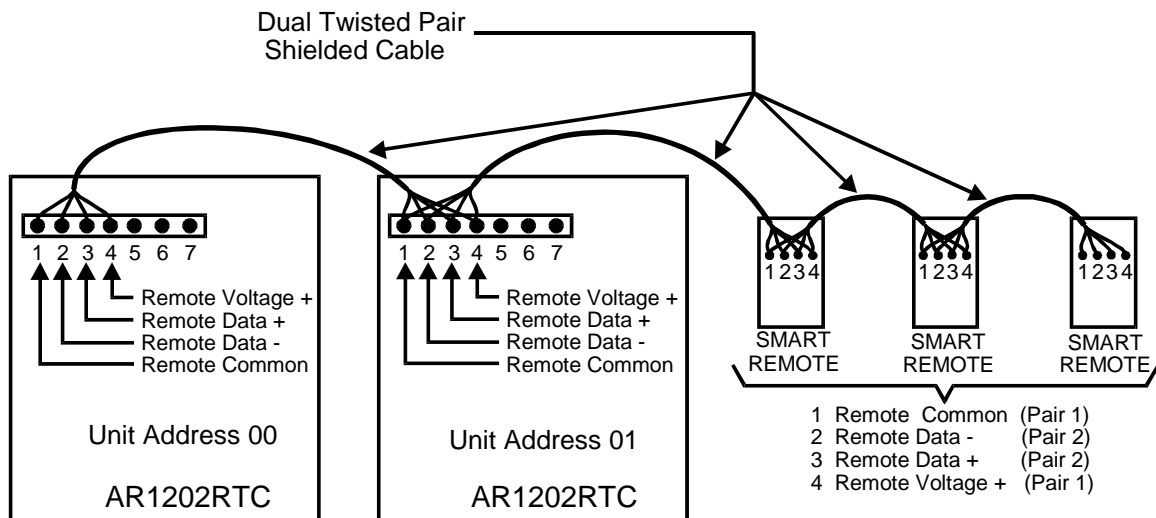

SIMPLE REMOTE CONNECTIONS

CAUTION
 REMOVE ALL POWER FROM THE AR1202
 BEFORE MAKING OR CHANGING SIMPLE
 REMOTE CONNECTIONS.

Scenes 1 - 7 (stored in the AR1202) may be accessed by simple remotes. A BLACKOUT function may also be accessed. A simple remote is any switch which can provide a momentary contact closure which can be applied to a specific pin on the AR1202 SIMPLE REMOTE CONNECTIONS terminal strip.

The SIMPLE REMOTE COMMON is routed to the remote switch.

When the switch is operated, the closure brings the common back to the applicable simple remote scene number connection point at the AR1202 terminal strip. Almost any available low voltage wire may be used since these connections are just contact closures.

Multiple simple remotes may be used. Additionally, multiple AR1202 units may be chained to one or more simple remotes.

See the diagram "EXTERNAL CONNECTIONS" and the example below for specific connection information.

SIMPLE REMOTE CONNECTIONS EXAMPLE USING A LIGHTRONICS APP01

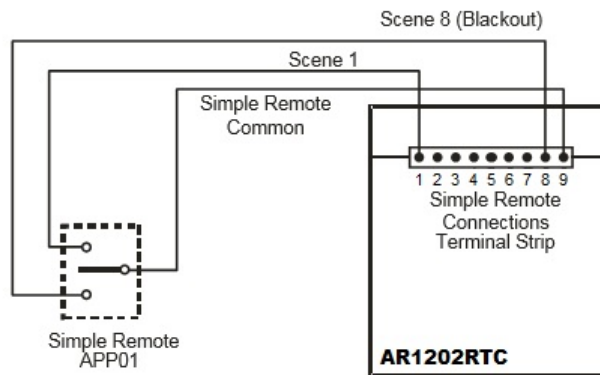

AR1202 UNIT SETUP

FRONT PANEL (PARTIAL VIEW)

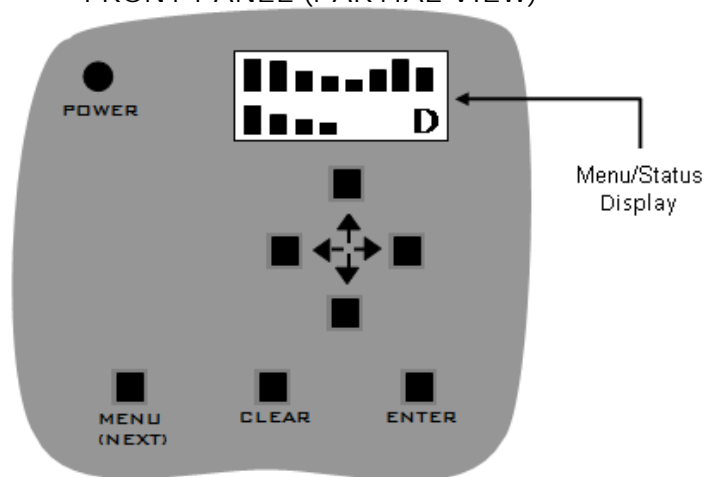

*Legacy units will have rectangular push-buttons rather than square push-buttons and may require a previous version of this manual.

AR1202 UNIT SETUP

The AR1202 must be set up (configured) as part of the installation process. This process is done from the AR1202 front panel using five menus described below.

SYSTEM SETUP should be done first. It includes setting the System Mode, System ID, and System Power Setup.

DIMMER SETUP should be done next. It includes Channel Limiting and Dim/Non-Dim selections.

DMX I/O SETUP must be performed if the unit will be used with a DMX controller. This setup assigns (patches) dimmer channels to DMX addresses and can lockout the wall remote stations.

SCENE SETUP must be performed to create scene presets to be activated from the remote control stations or by the clock/timer subsystem.

EVENT SETUP must be done if the clock/timer subsystem will be used. It includes Setting the Clock and Programming Events.

TOP LEVEL MENUS LAYOUT

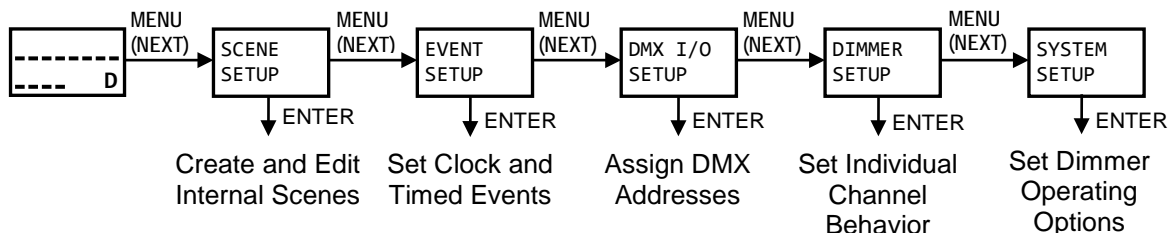

USING THE MENU SYSTEM

The **MENU (NEXT)** button steps through the five display menus. When one of these menus is displayed you can push the **ENTER** button to access that function. The **CLEAR** button will return the unit to its normal operating mode and cause the display to show the channel level bar graph. The **CLEAR** button DOES NOT clear entered values. The arrow buttons are used to set values for menu selections.

Use the ↑ and ↓ buttons to select the NORMAL mode. Push **ENTER** when finished.

SYSTEM MODE

The AR1202 currently uses only the NORMAL setting for system mode.

At the AR1202 front panel - push **MENU (NEXT)** until the System Setup menu appears on the status display.

SYSTEM POWER SETUP

CAUTION
TURN OFF ALL CHANNELS AND OPEN ALL CHANNEL CIRCUIT BREAKERS BEFORE CHANGING THE INPUT POWER SETUP.

In addition to making the correct power connections for the power source at your installation, the AR1202 must be set up to correctly respond to the power type.

At the AR1202 front panel - push **MENU (NEXT)** until the System Setup menu appears on the Status display.

Push **ENTER**. The System Mode menu will be shown.

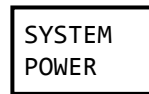
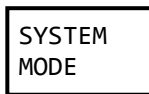
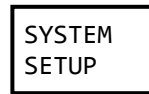
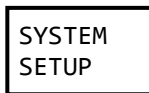

Push **ENTER**. The System Mode Selection menu will be shown.

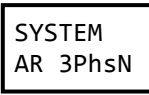
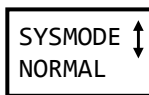

AR1202RTC ARCHITECTURAL DIMMER

Revision 2.01

OWNER'S MANUAL

05/01/2026

Use the ↑ and ↓ buttons to select a configuration corresponding to the actual power being supplied to the AR1202. Push **ENTER** when the correct power is shown. See the available choices below.

AR 1PhsN: Single Phase 120/240V Power Source
 AR 3PhsN: Three Phase 120/208V Power Source
 Normal Phase Rotation
 AR 3PhsR: Three Phase 120/208V Power Source
 Reverse Phase Rotation

There are two additional settings which are used only when it is not possible to provide actual 120/240V Single Phase power and the unit is being powered by two phases of a 120/208V Three Phase source.

AR 2PhsN: Two Phase 120/208V Power Source
 Normal Phase Rotation
 AR 2PhsR: Two Phase 120/208V Power Source
 Reverse Phase Rotation

NOTE: There are other settings available in this menu. These do not apply to the AR1202 dimmer.

You may not know in advance if you should use the Normal or Reverse rotation choice for Three Phase or Two Phase power. If this is the case then use NORMAL phase rotation initially.

NO damage will occur if the rotation is reversed, but dimming will not occur properly and some channels will appear to be in an on/off mode. This will be apparent when operating the unit. You can then change the setting.

UNIT ADDRESS ASSIGNMENT

When using a single AR1202 system, the unit address MUST BE SET TO 00. One (and only one) of the units in a multiple unit system must be set to address 00. Other units should be assigned in sequential order. This is required for proper smart remote operation.

At the AR1202 front panel - push **MENU (NEXT)** until the System Setup appears on the status display.



Push **ENTER**. Then push **MENU (NEXT)**. The System ID Set menu will be shown.

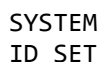

Push **ENTER**. The display shows the unit address.

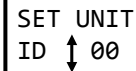

Set the desired address by using the ↑ and ↓ buttons.

Push **ENTER**. Then push **CLEAR** to return to the normal operating mode.

DIMMER CHANNEL SETUP

Individual channels within the AR1202 dimmer can be set for different behaviors. Any channel may be limited to a user selected maximum intensity level. Limiting applies to manual, scene, and DMX operation. Any channel may also be set to run as NON-DIM to act simply in an on/off manner.

CHANNEL LIMITING

At the AR1202 front panel - push **MENU (NEXT)** until the Dimmer Setup menu appears on the display.



Push **ENTER**. The Channel Limit menu will be shown.

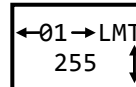

Use the ← and → buttons to select a channel. Then use the ↑ and ↓ buttons to set its limiting DMX value. Push **ENTER** when finished. The DMX limit range on the menu is between 10 and 255 which corresponds roughly to lighting intensity in between 4% and 100%.

CHANNEL DIMMER/NON-DIM MODE

Each channel can be operated in either a DIMMER mode or a NON-DIM mode. The NON-DIM mode still uses the SCRs in the AR1202 to control power, but operates in more of an on/off manner. Other options are found in this menu but are not widely used.

Push **MENU (NEXT)** until the Dimmer Setup menu appears on the display.



Push **ENTER**. Then push **MENU (NEXT)**. The display will show the menu:

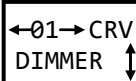

AR1202RTC ARCHITECTURAL DIMMER

Revision 2.01

OWNER'S MANUAL

05/01/2026

Use the ← and → buttons to select a channel. Then use the ↑ and ↓ buttons to switch between DIMMER and NON-DIM. Push **ENTER** when finished.

DMX I/O SETUP

DMX I/O Setup consists of two functions, Dimmer channel assignment and Smart Remote lockout.

DIMMER CHANNEL ASSIGNMENT

Dimmer channel assignment is used to assign individual AR1202 channels (circuits) to a DMX address. Each dimmer channel (1 - 12) can be patched to any of 512 DMX addresses.

At the AR1202 front panel - push **MENU (NEXT)** until the DMX I/O Setup menu appears on the display.

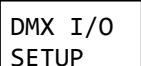

DMX I/O
SETUP

Push **ENTER**. The display shows AR1202 dimmer channels on the top line. The currently assigned DMX address is shown on the lower line prefixed by "DMX".

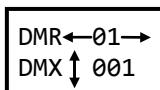

DMR ← 01 →
DMX ↑ 001

Use the ← and → buttons to select a dimmer channel. Then use the ↑ and ↓ buttons to assign it to a DMX address. Push **ENTER** after each channel assignment.

Push **CLEAR** to exit from the menu. It will not clear your settings.

DMX LOCKOUT

You can set any dimmer channel output to ignore DMX signal inputs from a DMX controller by assigning it to DMX address 000. This feature can be used with house lights or other special lighting. The channel will still respond to smart and simple wall remotes but the DMX input signal will be ignored.

SMART REMOTE LOCKOUT

The Smart Remote Lockout function prevents the AR1202 from responding to the smart remote wall stations when a DMX signal is present. Simple remote stations will still function.

NOTE: When feature is active, any active scenes will be turned off once DMX is applied.

At the AR1202 front panel - push **MENU (NEXT)** until the DMX I/O Setup menu appears on the display.

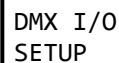

DMX I/O
SETUP

Push **ENTER**. Then push **MENU (NEXT)**. The display will show the lockout menu.

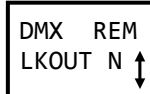

DMX REM
LKOUT N ↑

Use the ↑ and ↓ buttons to select Yes or No. Push **ENTER** when the desired state is shown.

CREATING AND EDITING SCENES

At the AR1202 front panel - push **MENU (NEXT)** until the Scene Setup menu appears on the display.



SCENE
SETUP

Push **ENTER**. The display shows the current scene number.

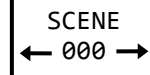

SCENE
← 000 →

Use the ← and → buttons to select the scene you want to set up and push **ENTER**. Scene 000 controls blackout fade time. Scene 001 is the first user scene.

There are three ways to create or set up a scene:

1. Set each channel intensity manually (EDIT SCENE).
2. Copy another existing scene (COPY SCENE). You can then edit the results.
3. Record a snapshot of the current channel intensities (RECORD LIVE NOW).

Push **MENU (NEXT)** to select one of the three methods described above. The display will show the corresponding menu.

TO CREATE A SCENE MANUALLY

Push **ENTER** when EDIT SCENE is shown.

The current dimmer channel number is shown on the display upper left. The current scene number (which was selected in the previous step) is shown on the display upper right. The settings for three dimmer channels are shown on the lower display row.

AR1202RTC ARCHITECTURAL DIMMER

Revision 2.01

OWNER'S MANUAL

05/01/2026

The LEFT channel on the display is the current dimmer channel (the channel which you will set the intensity level for).

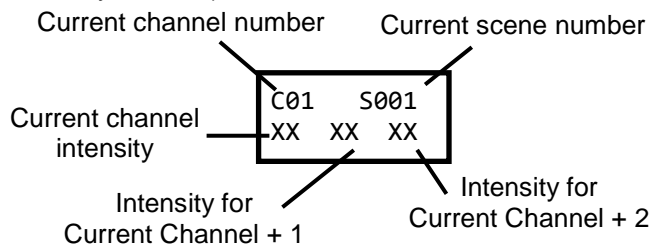

Use the ↑ and ↓ buttons to set the channel output intensity. The display shows the intensity setting as a number between 0% and 99%. A 100% setting is indicated by "FL". A "XX" setting means that the channel will be ignored for the current scene. This is useful when stacking of scenes is desired.

Push **ENTER** after each channel level is set.

Use the ← and → buttons to proceed to the next channel to be set up. The lower row of the display will shift to the left. Repeat the channel intensity selection for that channel.

Push **CLEAR** when all the channels for the selected scene are set. This will not clear your scene settings.

To setup another scene - repeat the process above using a different scene selection.

TO COPY A SCENE

Push **ENTER** when COPY SCENE is shown. The display will show a menu so you can select an existing scene to copy from.

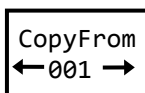

Use the ← and → buttons to select a scene. Then push **ENTER**. The scene will be copied and you will be transferred to the EDIT SCENE menu where you can further adjust the scene settings if desired.

TO RECORD A LIVE SCENE

A scene may be created by recording the current channel intensity levels.

Push **ENTER** when RECORD LIVE NOW is shown.

You will be transferred to the EDIT SCENE menu with the current settings. You can adjust these settings as shown above. Push **ENTER** to record the scene at these values.

SCENE FADE TIME

A fade time may be set individually for each scene. This is the time elapsed between a scene fully active and the next scene fully active. The factory default fade time is 3 seconds.

Fade time may be set between .5 and 99.5 seconds and is set from the SCENE SETUP menu (usually as you set channel intensities for the scene).

1. To set a scene fade time - Access the EDIT SCENE menu for the desired scene.
2. Use the ← and → buttons to move BEYOND the last channel (CHANNEL 16) for the scene. The display will indicate the current fade time for the scene.
3. Use the ↑ and ↓ buttons to set the desired fade time. Then push **ENTER**.
4. Push **CLEAR** to select another scene for fade time set up.

SCENE BLACKOUT FADE TIME

Fade time for the remote stations blackout function is set as an independent function.

The procedure is similar to that for other scenes except the blackout fade time is accessed by selecting SCENE 00 from the SCENE SETUP menu. Factory default fade time is 3 seconds. Blackout fade time may be set between 0.5 and 99.5 seconds. To select a fade time - use the ← and → buttons. Push **ENTER** when the desired time is shown.

OPERATION

MANUAL OPERATION

Individual dimmer channels may be operated from the AR1202 front panel. This is useful during testing and setup operations. Use the ← and → buttons to select a channel. The associated channel on the bar graph display will flash. Use the ↑ and ↓ buttons to set the lighting intensity for the selected channel.

Manual operation combines with DMX and remote stations settings but does not lock them out.

The **CLEAR** button will turn off all channels when operating manually.

AR1202RTC ARCHITECTURAL DIMMER

Revision 2.01

OWNER'S MANUAL

05/01/2026

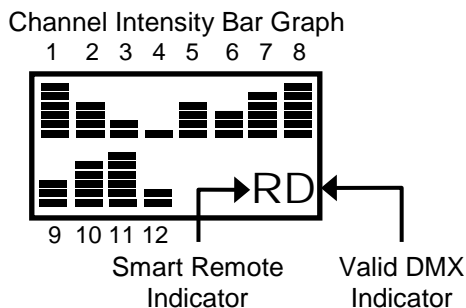

DMX CONTROLLER OPERATION

If a DMX signal is present when the AR1202 is turned on, it will automatically respond to it.

A "D" will be shown in the lower right corner of the LCD display if a valid DMX signal is present. Channel intensity levels will be shown on the bar graph display.

SMART REMOTES OPERATION (LitNet)

The AR1202 can store 100 preset scenes which may be activated by smart remotes. See the section "Creating and Editing Scenes" for information about programming the scenes. These scenes are grouped according to which type of smart remote can access them. Scenes 1 - 48 are reserved for push button and IR remotes. Scenes 51 - 99 are used with fader remotes. If multiple LitNet host units are connected to a smart remote, then each LitNet host will activate its own corresponding scene.

For a single dimmer system, when activity on the smart remote bus is sensed by the AR1202, an 'R' will be displayed on the screen. If multiple dimmers are connected together, the AR1202 assigned to Unit ID 00 will indicate 'R' only when there is activity from a smart remote station. AR1202 dimmers with a Unit ID of 01 or higher show an 'R' continuously as long as they have communication with the Unit ID 00 dimmer.

Both, push button and fader remotes may be connected to the same smart remote bus.

BUTTON AND IR SMART REMOTES OPERATION

These remotes activate individual scenes within a block of scenes which have been stored in the AR1202. Generally, users only have one scene on at a time. However, scenes can be stacked with the use of 'XX' as a setting for channels of each scene that will have a value assigned in other scenes being used together.

The remotes are set to specific blocks of scenes to be activated by the remote. You can select which block of scenes will be activated by the remote when ordering the remote or by contacting Lightronics technical support to reprogram. For instance, an AC1109 can be set to control scenes 1-8, 9-16, or other blocks of eight consecutive scenes. There are a total of six scene blocks available covering scenes 1 thru 48. Multiple remotes may be, but are not required to be, set to the same block of scenes.

The scene activation buttons will toggle. In other words, a scene will go OFF if you push its button while the scene is active.

The OFF button invokes a BLACKOUT for all scenes associated with that remote's scene block ID. Refer to the smart remote manual for specific information on scene addressing.

FADER SMART REMOTES OPERATION

These remotes activate specific individual scenes which have been stored in the AR1202 on a "pile on" basis. In other words, multiple scenes will merge together in a "greatest of" fashion. This means the intensity of any given channel will go to the highest level of all the scenes which use it. If multiple fader stations are in use in a system, the AR1202 will follow a last takes precedence protocol for common scenes between fader stations.

Fader remotes are scene block addressable so you can select which scenes it activates. There are three scene blocks available. Each block includes 16 scenes. The first block starts at scene 51. This refers to the lowest numbered fader on the remote. The other faders on that remote will use the next consecutively numbered scenes (52, 53, 54, etc.). The second and third scene blocks begin at scene 67 and 83 respectively. Multiple remotes of this type may be, but are not required to be, set to the same block of scenes.

The OFF button invokes a BLACKOUT for all scenes associated with that remote's scene block ID. Refer to the fader smart remote owner manual for specific information on setting scene blocks.

SIMPLE REMOTES OPERATION

Scenes 1 - 7 (stored in the AR1202) may be accessed by simple remotes. A BLACKOUT FUNCTION may also be accessed. A simple remote is any switch which can provide a momentary contact closure that can be applied to a specific pin on the AR1202

SIMPLE REMOTE UNIT INPUTS terminal strip. Lightronics currently offers an APP01 simple remote.

The APP01 is a "center off, single pole, double throw, momentary contact, toggle switch." It can be used as a simple entrance switch to activate a scene when someone enters/exits an area. Alternative devices such as relays, timers, and motion sensors can be connected to AR1202 dimmers as simple remotes. These are available from a variety of manufacturers.

The momentary completion of a circuit path between the simple common terminal and one of the scene terminals will activate the respective scene.

EVENT SYSTEM OPERATION

The AR1202 includes an internal clock and timer sub system. This subsystem may be used to create events which activate and switch between preset lighting scenes based upon times, days, and dates. A total of 128 events may be programmed.

The clock will still operate without AC power for approximately two weeks and does not require a battery. Event settings are retained in non-volatile memory; therefore, they will not be lost if the AR1202 is powered off.

An event is used to trigger any one of 100 scenes which have been previously created and stored in the AR1202. Any scene may be used by multiple events. A scene may be set to turn ON, turn OFF, or be ignored by an event.

An event may be set to trigger based on a date of the year and a time. This enables scene activation for one time or infrequent occurrences such as holidays.

An event may also be set to trigger on a daily or multiple times per day basis. Additionally, specific days of a week can be designated to be used or skipped. This is a more common type of operation where events are triggered on a regular schedule.

EVENT SYSTEM ENABLE

Events programmed in the AR1202 will not trigger unless the event system is set to ON. If the event system is OFF you can still set the clock and program event times and dates but they will never be triggered.

Setting events to OFF is used to prevent inadvertent triggers which may have been forgotten about, incorrectly set, or when events are no longer required.

TO CONTROL EVENT TRIGGERING

Push **ENTER** from the Event Setup menu. The display will show the event system ON/OFF menu.

```
EVENT
SYS_OFF ↓
```

Use the ↑ and ↓ button to select ON or OFF. Push **ENTER** when the desired ON/OFF state is shown.

SETTING THE INTERNAL CLOCK

The clock must be set to the correct date, time and day of the week in order to operate correctly. This is performed from the AR1202 Event Set Clock menu

At the AR1202 front panel - push **MENU (NEXT)** until the EVENT SETUP menu appears on the display.

```
EVENT
SETUP
```

Push **ENTER**. Then push **MENU (NEXT)**. The EVENT SET CLOCK menu will be shown.

```
EVENT
SETCLOCK
```

Push **ENTER**. The SET DATE menu will be shown.

```
SET DATE
00/00/00
```

SETTING THE DATE

Use the ← and → buttons to select the month, day, or year and then use the ↑ and ↓ buttons to set the value. Push **ENTER** after setting each value. Push **MENU (NEXT)** to proceed to the SET TIME menu.

SETTING THE TIME OF DAY

```
SET TIME
00:00
```

Use the ← and → buttons to select either hours or minutes and then use the ↑ and ↓ buttons to set the value. The format for hours is 00 to 23, not AM/PM. Push **ENTER** after setting each value.

Push **MENU (NEXT)** to proceed to the SET DAY menu.

```
SET DAY
MONDAY
```

SETTING THE DAY OF THE WEEK

The day of the week **MUST BE SET** when setting or changing the date. It does not automatically synchronize to the date setting. Once the day is correctly set, it will continue to track the date.

Use the ↑ and ↓ buttons to select the day so it corresponds correctly to the previously set date. Push **ENTER** when the correct day is shown.

A complete layout diagram of the menus for setting the clock is shown below.

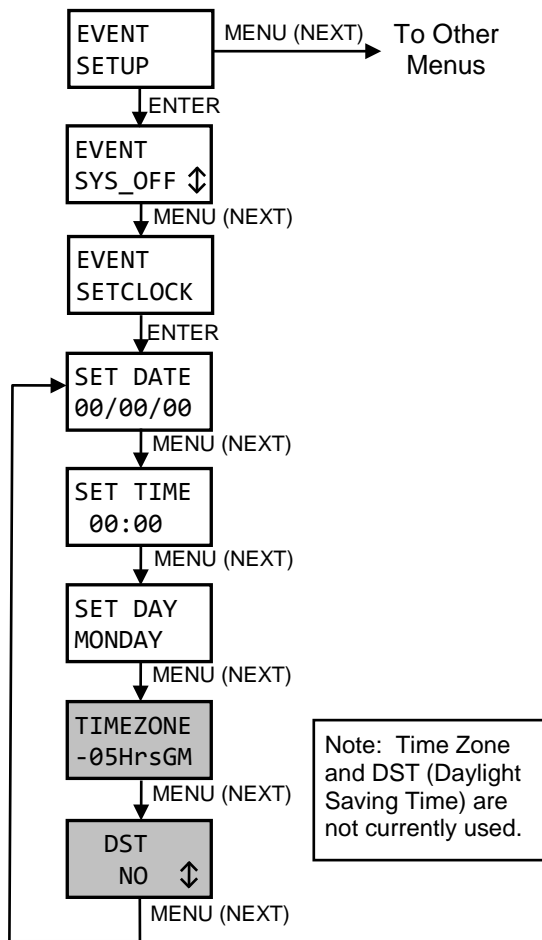

PROGRAMMING EVENTS

Events are programmed using the AR1202 Event Editor menus.

Programming an event consists of four steps:

1. Select the event you want to set up (1 - 128).
2. Assign a scene (1 - 100) to the event.
3. Select what action is to be performed for that scene (Turn it ON, Turn it OFF, or IGNORE IT).

4. Assign the DATE / TIME or DAY(S) / TIME for the event to be triggered.

The menu layout is shown below.

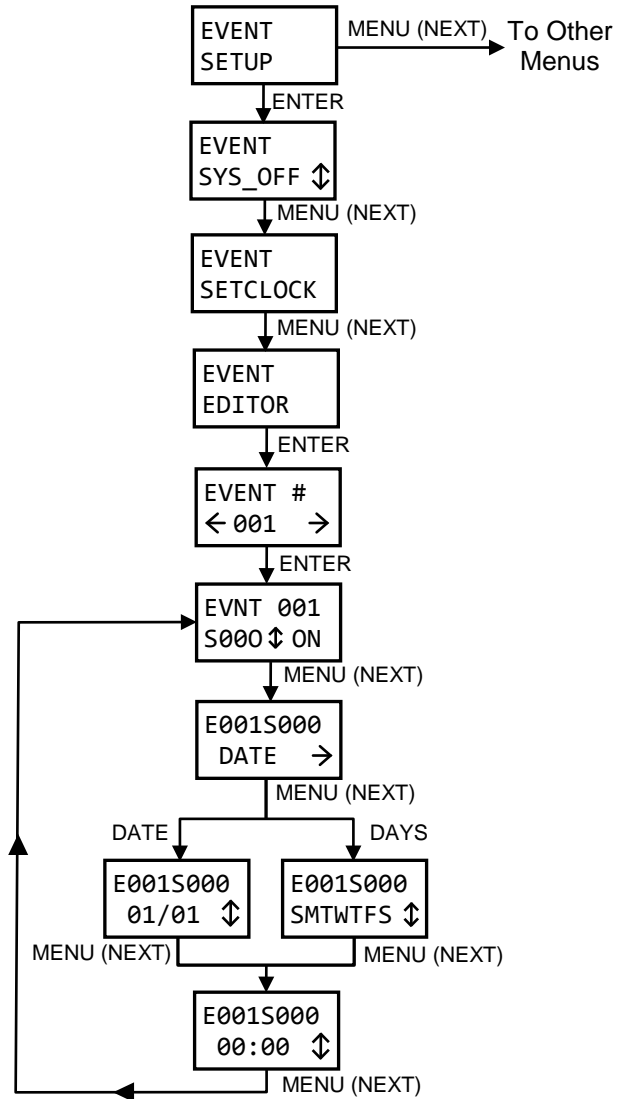

SELECTING AN EVENT

From the EVENT EDITOR menu - Push **ENTER**. The display will show the event selection menu as follows.

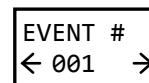

If an event already has a scene assigned to it then the event number will be followed by an asterisk (*).

Use the ← and → buttons to select the event number. Then push **ENTER** to proceed to the scene number and scene action menu. If you push and hold down

AR1202RTC ARCHITECTURAL DIMMER

Revision 2.01

OWNER'S MANUAL

05/01/2026

the ← or → button - the event number will skip to the next programmed event and stop.

ASSIGNING A SCENE AND SCENE ACTION

The top row of this menu shows the number of the event you are working on. The bottom row shows the assigned scene and the action to perform.

```

EVNT 001
S000 ↕ ON
  
```

Use the ← and → buttons to select either the scene number or action. Your selection is indicated by flashing that part of the menu. Use the ↑ and ↓ buttons to change the value. Scenes 0 - 100 may be assigned. Available actions are ON, OFF, and XXX (IGNORE). Push **ENTER** once a value has been selected. A setting of XXX disables the event even if a scene for it has been set.

Push **MENU (NEXT)** to proceed to the next menu or push **CLEAR** to return to the event number selection menu.

CHOOSING DATE OR DAY BASED EVENTS

This menu enables selection of either DATE based or DAY based operation. The menu will show either

```

E001S000    OR    E001S000
DATE →      DAYS →
  
```

The top row shows the event number and scene number you are working on.

Use the ← and → buttons to switch between DATE and DAYS. Push **MENU (NEXT)** to proceed to the next menu for setting the date or day and the time of day. Push **CLEAR** to return to the event number selection menu.

SETTING DATE BASED TRIGGERS

The top row of these menus show the event and scene number you are working on.

The bottom row is used to set the trigger date and the time of day.

To set the date:

```

E001S000
01/01 ↕
  
```

Use the ← and → buttons to select either the month or day of the month. Your selection is indicated by flashing that part of the menu. The date format is MM/DD (month on the left). Use the ↑ and ↓ buttons to change the value. Push **ENTER** once a value has been selected.

CAUTION: If you set an invalid date (such as February 30th) there will be no warning and the event will NEVER trigger.

Push **MENU (NEXT)** to proceed with setting the trigger time or push **CLEAR** to revert to the event number selection menu.

To set the trigger time:

```

E001S000
00:00 ↕
  
```

Use the ← and → buttons to select hours or minutes. Your selection is indicated by flashing that part of the menu. The format for hours is 00 - 23 (not AM/PM). Use the ↑ and ↓ buttons to change the value. Push **ENTER** once a value has been selected.

Push **MENU (NEXT)** to return to the SCENE NUMBER and SCENE ACTION menu or push **CLEAR** to revert to the event number selection menu.

SETTING DAY BASED TRIGGERS

The top row of these menus show the event number and scene number you are working on. The bottom row is used to set the trigger days and the time of day.

To set days of the week:

```

E001S000
SMTWTFS ↕
  
```

The bottom menu row shows the days. If a day shows as a solid block (■) instead of a character, then the event will be skipped (will not trigger on that day).

Use the ← and → buttons to select a week day. Then use the ↑ and ↓ buttons to change between trigger and skip. Push **ENTER** once a value has been selected.

Push **MENU (NEXT)** to proceed with setting the trigger time or push **CLEAR** to revert to the event number selection menu.

To set the trigger time:

```

E001S000
00:00 ↕
  
```

Use the ← and → buttons to select hours or minutes. Your selection is indicated by flashing that part of the menu. The format for hours is 00 - 23 (not AM/PM). Use the ↑ and ↓ buttons to change the value. Push **ENTER** once a value has been selected.

Push **MENU (NEXT)** to revert to the SCENE NUMBER and SCENE ACTION menu or push **CLEAR** to revert to the event number selection menu.

AR1202RTC ARCHITECTURAL DIMMER

Revision 2.01

OWNER'S MANUAL

05/01/2026

MAINTENANCE AND REPAIR

OWNER MAINTENANCE

There are no user serviceable parts inside the unit.

INTERNAL FUSE

WARNING



MAKE CERTAIN POWER IS REMOVED
FROM THE FEED CIRCUITS
BEFORE HANDLING THE UNIT.



The AR1202 has a 1/2 amp, 250V, Type ABC, fast acting fuse on the inside of the cabinet. It provides protection only for the internal electronic control circuitry. It may be replaced ONLY by a fuse of identical type and size.

Contact a qualified electrical maintenance person if you suspect this fuse has blown.

HIGH VOLTAGE CIRCUITRY IS EXPOSED WHEN THE CABINET DOOR IS OPEN. DO NOT ALLOW THE UNIT TO OPERATE OR HAVE POWER APPLIED TO IT WHILE THE DOOR IS OPEN.

The best way to prolong the life of your unit is to keep it cool, clean, and dry. It is important that the cooling intake and exit vent holes are clean and unobstructed.

Service by other than Lightronics authorized agents may void your warranty.

TROUBLESHOOTING

Note: Annotate any current settings prior to making changes.

Single/Multiple channels not dimming properly.

1. Check System Setup - System Power.
2. Check Dimmer Setup - Channel Mode.

No power on individual channels.

1. Verify channel breaker is in ON position.
2. Check Dimmer Setup - Channel Limit.
3. Use Manual Operation to determine if this is actually a DMX/remote control issue.

No response to DMX.

1. Confirm there is a 'D' on the display screen.
2. If there is no 'D' on the display, check other DMX equipment in the system.
3. Check DMX I/O Setup - Dimmer Channel Assignment.

4. Verify DMX settings in the DMX controller.

No Smart Remote operation.

1. Check System Setup - System Mode
2. Check System Mode - System ID
3. Check DMX I/O Setup - DMX Remote Lockout
4. Verify Scene Setup programmed for desired operation.

No output, LCD display or response from AR1202.

1. If the Power LED is off or flashing, contact Lightronics Service Department or a qualified electrical maintenance person.

OPERATING AND MAINTENANCE ASSISTANCE

If service is required, contact the dealer from whom you purchased the equipment or contact:

Lightronics, Service Department
509 Central Drive
Virginia Beach, VA 23454
TEL 757 486 3588.

Lightronics recommends you record the serial number of your unit for future reference. This is likely located on the left side of the AR cabinet on a small sticker that has "AR1202" or "AR1202-6" and a series of numbers below it on the same sticker. This is typically in the format 1234-56789.

SERIAL NUMBER _____

WARRANTY INFORMATION AND
REGISTRATION - CLICK LINK BELOW

www.lightronics.com/warranty.html

CONTROL CIRCUIT BOARD CONNECTIONS

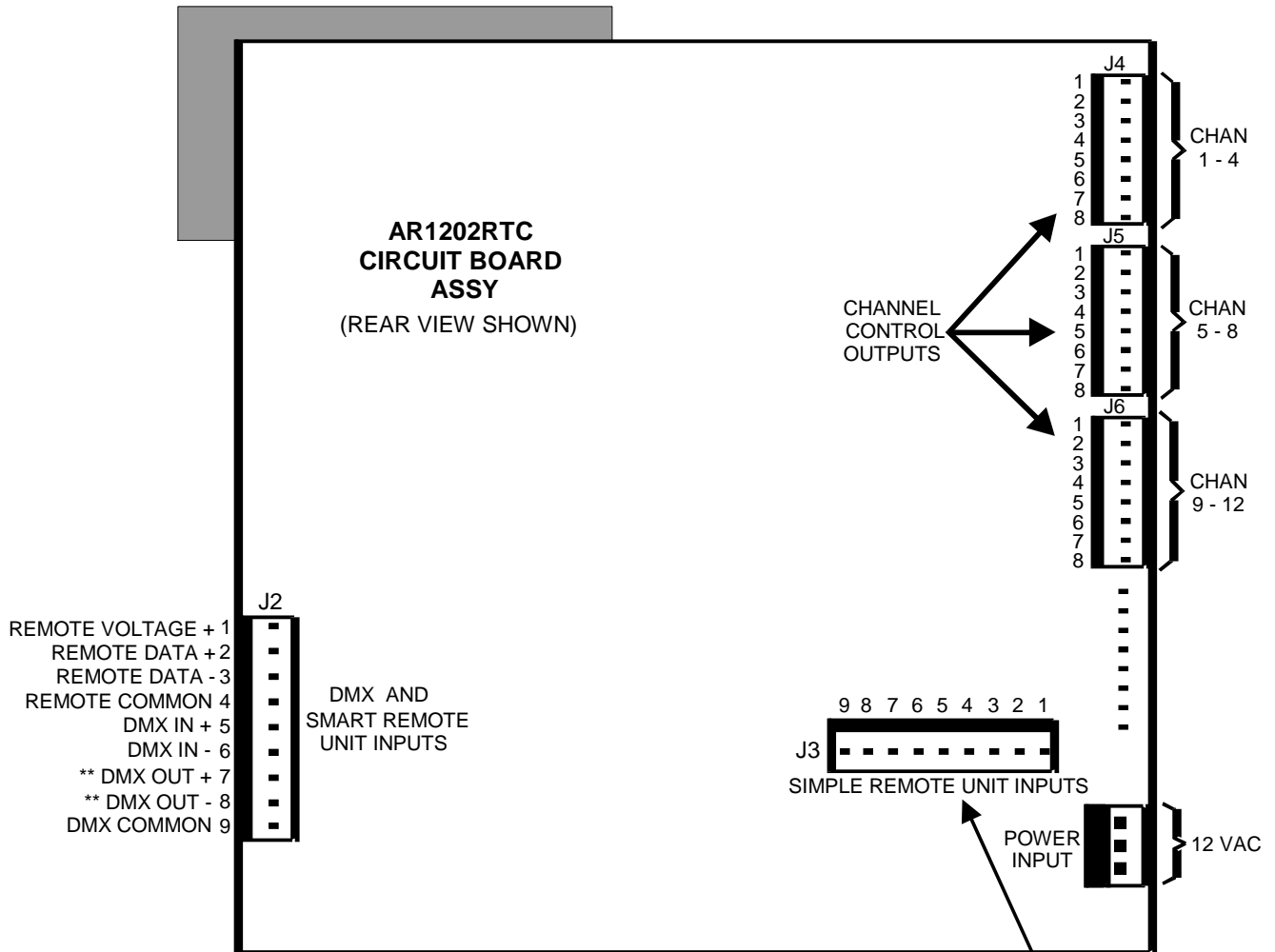

** DMX OUT connections are no longer used

SIMPLE REMOTE UNIT INPUT CONNECTIONS (J3)	
PIN #	FUNCTION
1	SCENE #1
2	SCENE #2
3	SCENE #3
4	SCENE #4
5	SCENE #5
6	SCENE #6
7	SCENE #7
8	SCENE #8 ◆
9	REM. COMMON

◆ Dedicated to "blackout" function

AR1202RTC ARCHITECTURAL DIMMER
OWNER'S MANUAL

Revision 2.00

05/11/2023

DIMENSIONS AND MOUNTING

Cabinet Front View with Door Removed

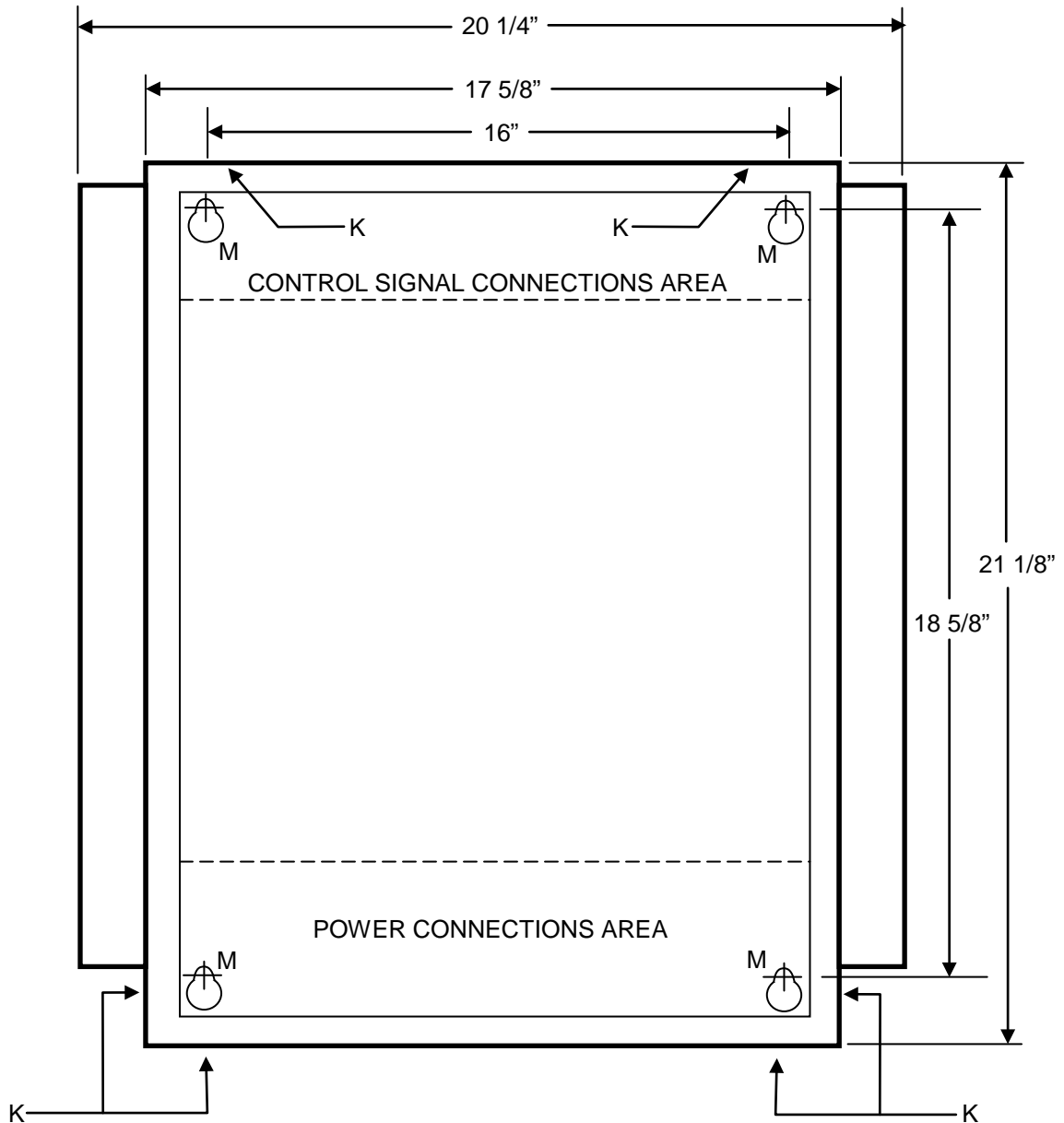

NOTES:

Dimensions are +/- 1/16". This drawing is not to scale.

Cabinet Clearance Depth is 6 1/4"

Mounting holes indicated by "M" will accommodate 1/4" bolt.

Double 1/2, 3/4 inch knockout holes provided at locations indicated by "K".

Suggested Mounting Procedure:

Drill top holes level, 16" apart at desired height.

Partially install bolts (enough to hold cabinet weight).

Hang cabinet from top bolts.

Drill lower holes and install lower bolts – tighten all bolts.

AR1202 UNIT SPECIFICATIONS

CHANNELS/CAPACITY:	12 Channels @ 2400 watts each channel
POWER REQUIREMENTS: (AR1202RTC)	120/208VAC three phase, 80 amps each line OR 120/240VAC single phase, 120 amps each line
POWER REQUIREMENTS: (AR1202-6RTC)	120/208VAC three phase, 40 amps each line OR 120/240VAC single phase, 60 amps each line
POWER DEVICES:	Dual 65 amp SCRs
POWER CONNECTOR:	Terminal strip
CHANNEL OUTPUT:	Terminal Strip
CIRCUIT BREAKERS:	20 amp fast acting
MINIMUM LOAD:	15 watts
CURVE:	Modified square law
FILTER RISE TIME:	600 usec. minimum
OUTPUT FUNCTION:	DIMMER or NON-DIM selectable
CONTROL INPUT:	DMX512 USITT standard
FRONT PANEL:	8 char. x 2 line LCD display
LITNET NETWORK:	RS-485, 62.5 Kbaud, bidirectional 9 bit network
LOCAL PRESETS:	100 scenes standard. Expandable to 255 scenes
CLOSURE INPUT:	8 inputs for single, dual button, or combine stations
LITNET STATIONS:	Total of 32 LitNet stations with unique system addresses
SLAVE UNITS:	Up to 31 additional units may be added
SIZE:	21 1/8"H x 20 1/4"W x 6 1/4"D
WEIGHT:	61 lbs. (70 lbs. shipping weight)